

## Table 1 Properties of Sections

### Case 4 Tee Section

#### Tee section

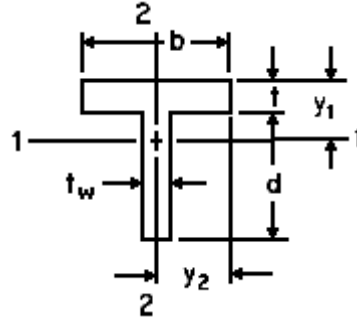

#### Notation file

Provides a description of Table 1 and the notation used.

#### Enter dimensions

Base:

$$b \equiv 3 \cdot \text{in}$$

Height:

$$d \equiv 3.5 \cdot \text{in}$$

Flange thickness:

$$t \equiv 1 \cdot \text{in}$$

Web thickness:

$$t_w \equiv 0.5 \cdot \text{in}$$

#### Area

$$A := t \cdot b + t_w \cdot d$$

$$A = 4.75 \text{ in}^2$$

#### Distances from centroid to extremities

$$y_1 := \frac{b \cdot t^2 + t_w \cdot d \cdot (2 \cdot t + d)}{2 \cdot (t \cdot b + t_w \cdot d)} \quad y_1 = 1.329 \text{ in}$$

$$y_2 := \frac{b}{2} \quad y_2 = 1.5 \text{ in}$$

## Moments of inertia

$$I_1 := \frac{b}{3} \cdot (d + t)^3 - \frac{d^3}{3} \cdot (b - t_w) - A \cdot (d + t - y_1)^2$$

$$I_1 = 7.632 \text{ in}^4$$

$$I_2 := \frac{t \cdot b^3}{12} + \frac{d \cdot t_w^3}{12} \quad I_2 = 2.286 \text{ in}^4$$

## Radii of gyration about central axes:

$$r_1 := \sqrt{\frac{I_1}{A}} \quad r_1 = 1.268 \text{ in}$$

$$r_2 := \sqrt{\frac{I_2}{A}} \quad r_2 = 0.694 \text{ in}$$

## Plastic section moduli

$$Z_1 := (t_w \cdot d < b \cdot t) \cdot \left[ \frac{d^2 \cdot t_w}{4} - \frac{b^2 \cdot t^2}{4 \cdot t_w} + \frac{b \cdot t \cdot (d + t)}{2} \right] + (t_w \cdot d \geq b \cdot t) \cdot \left[ \frac{t^2 \cdot b}{4} + \frac{t_w \cdot d \cdot \left( t + d - \frac{t_w \cdot d}{2 \cdot b} \right)}{2} \right]$$

$$Z_1 = 3.781 \text{ in}^3$$

$$Z_2 := \frac{b^2 \cdot t + t_w^2 \cdot d}{4} \quad Z_2 = 2.469 \text{ in}^3$$

## Shape factors

$$SF_1 := \frac{Z_1 \cdot (d + t - y_1)}{I_1} \quad SF_1 = 1.571$$

$$SF_2 := \frac{Z_2 \cdot b}{2 \cdot I_2} \quad SF_2 = 1.62$$

## Location of plastic neutral axis

If  $t_w \cdot d < b \cdot t$ ,  $y_p$  is measured from the bottom;  
otherwise, it is measured from the top.

$$y_p := (t_w \cdot d < b \cdot t) \cdot \left( \frac{b \cdot t}{2 \cdot t_w} + \frac{d}{2} \right) + (t_w \cdot d \geq b \cdot t) \cdot \left( \frac{t_w \cdot d}{2 \cdot b} + \frac{t}{2} \right)$$

$$y_p = 4.75 \text{ in}$$

---