

Pro/ENGINEER® Tolerance Analysis Extension Powered by CETOL™ Technology

ANALYZE GEOMETRIC TOLERANCE AND VARIATIONS

To deliver high quality products to market faster, designers must understand tolerances and the impact of manufacturing variation on their product designs.

With Pro/ENGINEER Tolerance Analysis Extension (TAX) powered by CETOL Technology, design engineers gain powerful tolerance analysis capabilities within their design environment. You can easily analyze, visualize and understand the geometric tolerance stack-up and dimensional variation that impacts your design.

Optimize Design For Manufacturability

Designers need best-in class solutions to meet the challenging demands of a competitive global marketplace. Designers must be able to see tolerances and variations on their design models, analyze sensitivities, and visualize cumulative tolerances in order to understand the impact, and engineer robust designs that won't fail downstream in the manufacturing process. Analyzing and incorporating manufacturing tolerances and variation constraints early in the design process saves both time and cost.

Pro/ENGINEER TAX powered by CETOL Technology, provides a robust tolerance stack-up and gap analysis solution that is seamlessly integrated into the design environment. You can evaluate the impact of tolerances and dimensioning schemes on the feasibility of product designs. The result: shorter product development cycles, lower product cost, and higher product quality.

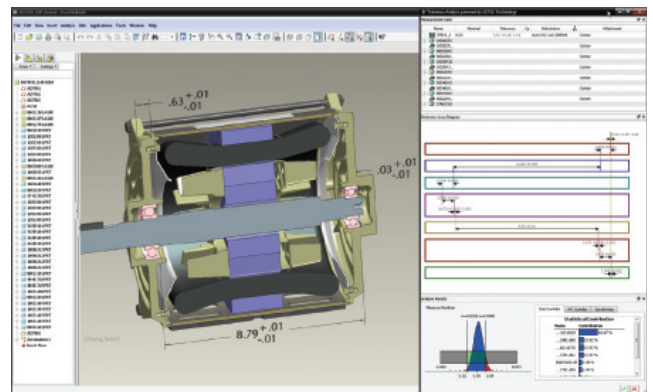

Easy-to-use, powerful tolerance analysis capabilities are now integrated directly into the Pro/ENGINEER design environment with Pro/ENGINEER TAX powered by CETOL Technology.

Key Benefits

- Evaluate the impact of tolerances on the manufacturability of designs
- Enable concurrent engineering, to ensure designs meet manufacturing requirements
- Six Sigma design methodologies to ensure design quality
- Streamline design processes, improve productivity and reduce time-to-market

Faster Tolerance Analysis

Feature and Specifications

Easy-to-Use Capabilities

- 1D tolerance loops
- Tolerance stack-ups
- Automatic validation of dimensions and dimension loop
- Interactive visualization of the tolerance loop
- Profile and position GTOLS supported
- Tolerance analyses saved with Pro/ENGINEER model
- Part or assembly-level management of tolerance analyses
- Ability to interactively modify tolerance values

Powerful Analysis

- Contribution and sensitivity analysis
- Configurable biasing of pin/hole joints
- Worse-case and statistical analysis
- Reference driving as well as annotation dimensions

Results

- Contribution and sensitivity output plots
- Automatically generated HTML results report
- View worst case and statistical distributions
- Mean and standard deviation
- Dynamic display of results within the Tolerance Analysis Feature

Language Support

English, German, French, Italian, Spanish, Japanese, Chinese (Simplified and Traditional) and Korean

Platform Requirements

Microsoft Windows (Vista and XP)
UNIX platforms (Solaris and HP-UX)

For the most up-to-date platform support information, please visit www.ptc.com/partners/hardware/current/support.htm

For more information on the Pro/ENGINEER Tolerance Analysis Extension powered by CETOL Technology visit www.ptc.com/go/proengineer

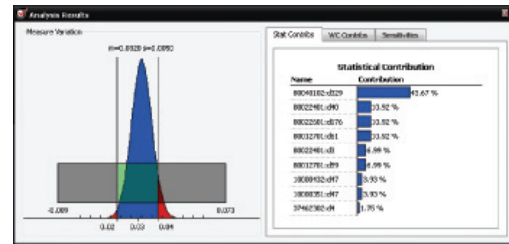
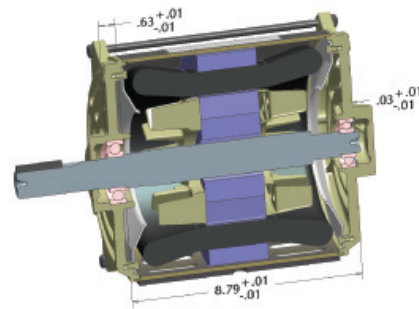

Pro/ENGINEER TAX powered by CETOL Technology lets you graphically view variation and statistical contribution results.

The Pro/ENGINEER Advantage

Pro/ENGINEER is simple to learn and use, and is available in a variety of packages designed to meet your company's specific needs. Whether you need a cost-effective 3D CAD system that contains all the basic design capabilities, or a comprehensive Product Development System that seamlessly connects your extended supply chain, you'll find exactly what you need in a single, fully scalable solution. Choose the package that fits your needs today. As your needs change and grow, you can easily upgrade to the package that is right for you tomorrow, which leverages the same powerful platform – this means no data translation and a consistent user experience.

Pro/ENGINEER Tolerance Analysis Extension powered by CETOL Technology enables designers to create products that are designed for manufacturability. As part of the Pro/ENGINEER family of integrated 3D CAD/CAM/CAE solutions, it delivers a distinct advantage for engineers and designers because Pro/ENGINEER is fully associative. That means any change made to the design is automatically reflected in all downstream deliverables – without any translation of model information. By eliminating data translation, you not only save time, but you also avoid the possibility of translation errors in your design. Pro/ENGINEER gives you everything you need to create and quickly update high-quality, winning designs.